

LAURINI PIPELAYERS

TECHNICAL DATA SHEET



Laurini Officine Meccaniche Srl

Località Spigarolo, 43011 Busseto (PR), Italy
Phone: +39 0524.91844 Fax: +39 0524.91428
www.laurini.com
E-mail: laurini@laurini.com
VAT IT 02164990349

SansOne 45



SansOne 45 is our most compact machine and is characterized by an *undercarriage variable gauge*, to facilitate transport and guarantee superior stability to all other machines of the same size. The seat rotates together with all the controls positioned on the armrests and allows the operator to work without having to turn his neck.

The machine is equipped with ROPS protection, in which a closed cab with wide visibility, with heating and air conditioning can be mounted. The integrated anti-tipping system processes the position of the counterweight, adapting the relative lifting capacity, showed on a 12" display.



LAURINI
PIPELAYERS

SansOne 45

TECHNICAL DATA SHEET

Technical Data

Engine	CAT C7.1 - da 225HP@2200rpm - EU Stage V
Hydrostatic transmission	Danfoss
Machine Weight - working configuration	36.000,00 kg
Speed	6,0 km/h
Operator protection	Roll-bar ROPS-FOPS
Maximum load capacity	45 ton
Winches	Max speed 80 mt/min
Ropes	19 mm diameter
Standard arm	6,5 mt
Track shoes width	610 mm
Track length	3660 mm

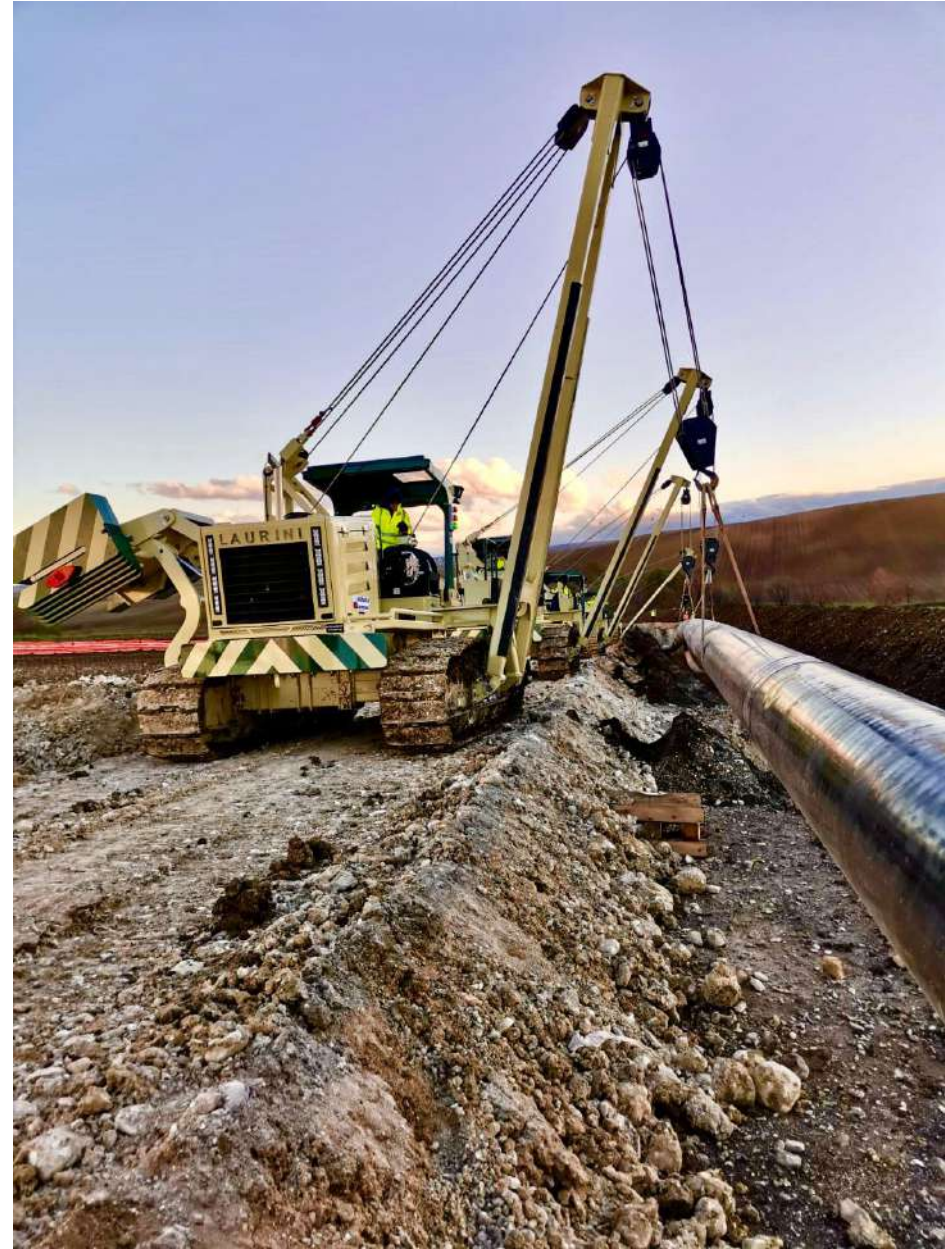

LIFTING CAPACITY WITH EXTENDED COUNTERWEIGHT

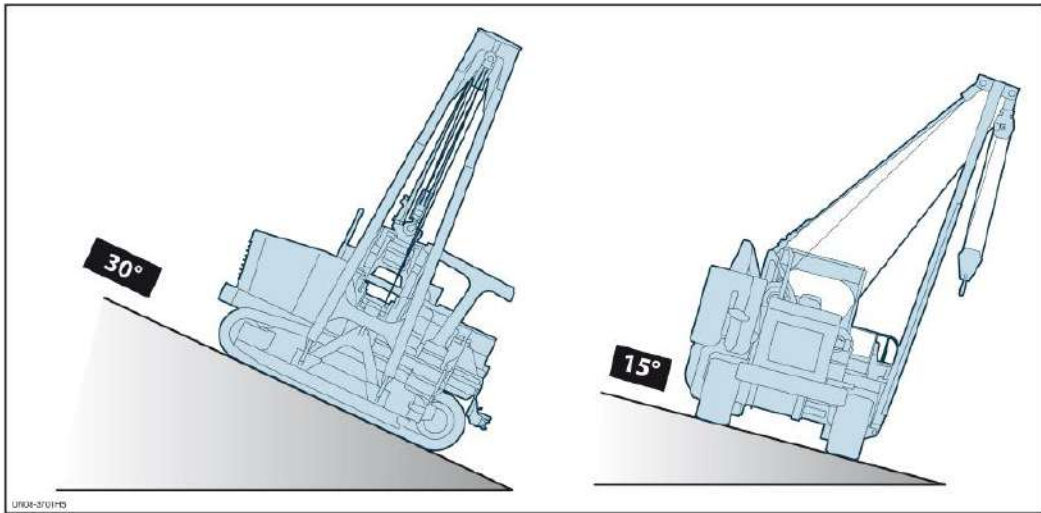
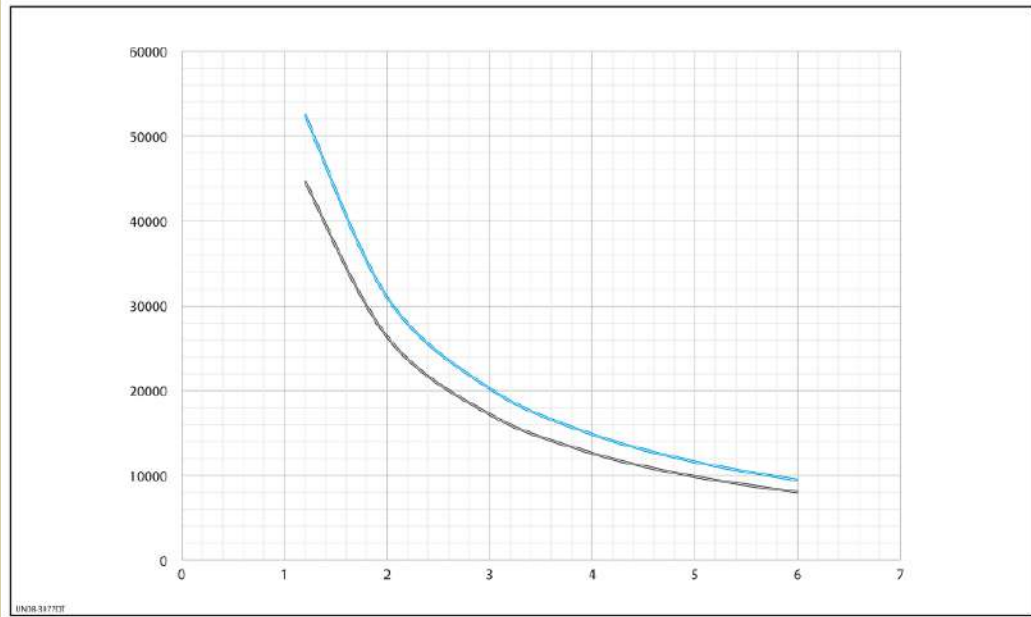

MAXIMUM SLOPE

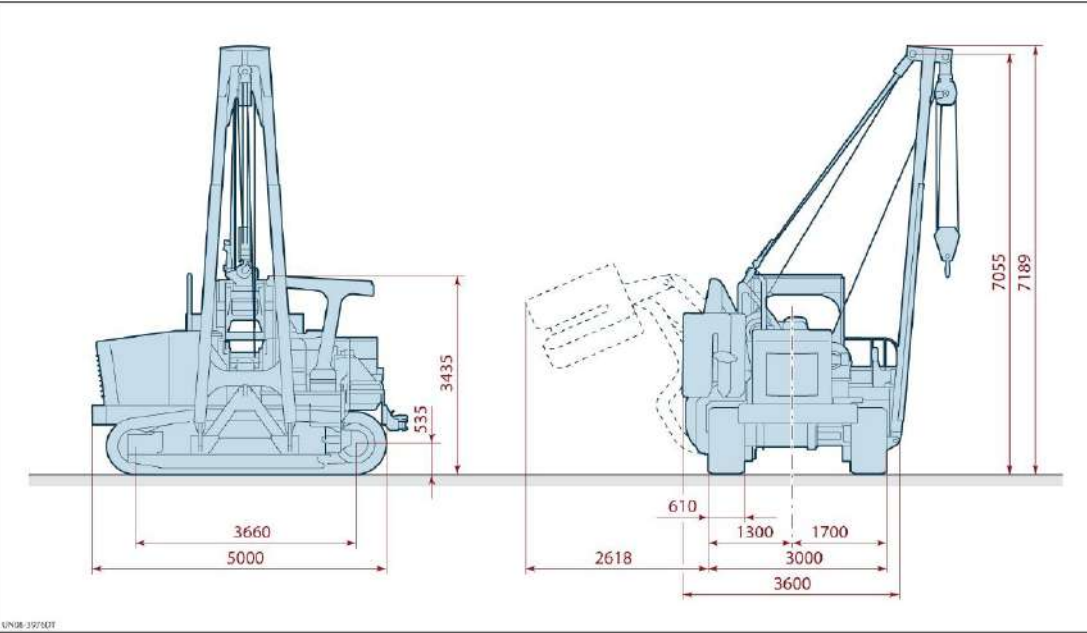
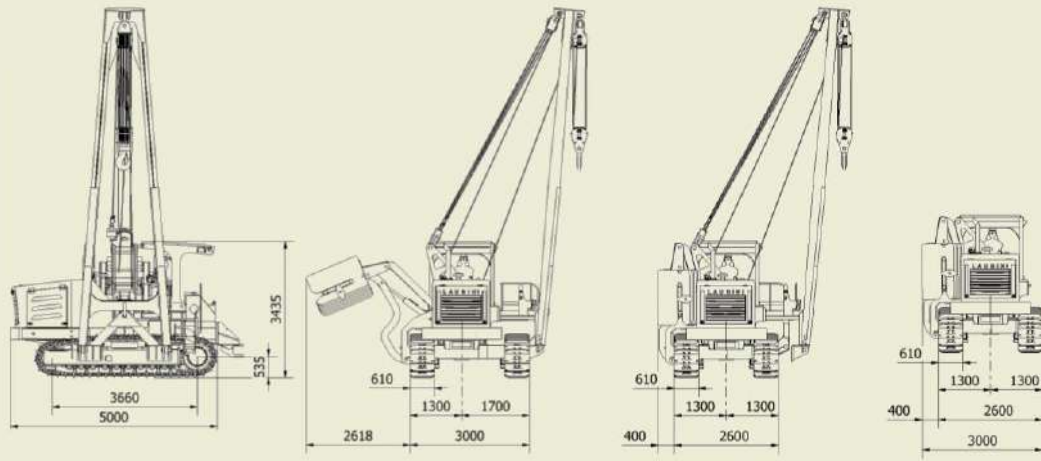

LAURINI
PIPELAYERS

SansOne 45

TECHNICAL DATA SHEET