

LAURINI SETTANTA PIPELINER

EQUIPPED
WITH  **DECKHAND**[®]

Developed through an industry-leading collaboration between Laurini and LaValley Industries, the **SETTANTA PIPELINER** was engineered from the ground up to prioritize lifting and handling as its primary functions.

 **LaValley Industries**[®]
Learn more at
LAVALLEYINDUSTRIES.COM

PIPELINER

TECHNICAL SPECIFICATIONS

LIFTING CAPACITY
39 TONS

OPERATING WEIGHT
(WITHOUT BOOM)
40 TONS

ENGINE SIZE
350 HP

BOOM CONFIGURATIONS
**DECKHAND
PIPELAYER
DIGGING**

CAB ELEVATION
5.5 FT / 1.7 M

VARIABLE GAUGE
UNDERCARRIAGE
**EXTENDED: 14.4 FT (4.4 M)
RETRACTED: 9.5 FT (2.9 M)**

SWING RADIUS
360 DEGREES

PLATFORM
SETTANTA



PIPELINER PRODUCT FEATURES

- Prioritizes lifting and handling as primary functions
- Integrated DECKHAND pipe handling system
- True 360° lifting capability
- Hydraulic variable gauge undercarriage
- Interchangeable booms for pipe handling, lowering in, digging
- Quick Connect System allows for easy connectivity with hydraulics and electronics
- Elevated cab with FOPS as a standard feature
- Anti-Tip System monitors safe lifting limits
- Dedicated auxiliary hydraulic gear pump
- All parameters controlled through In-Cab Display

INTEGRATED DECKHAND FEATURES

- 360° continuous load rotation for maximum versatility
- Safely monitor and adjust functions, working parameters, and hydraulic settings from the In-Cab Display
- DECKHAND AutoClamp™ electronic safety system features proximity sensors and Lift Lights to continuously indicate and monitor load status
- Load hold valves and Pipe Arm geometry maintain grip security regardless of hydraulic pressure status
- Shift Function allows each arm to independently shift 5.5 inches along the Main Beam
- Positive grip maintained in rain, snow, and high winds

SAFER, BETTER, FASTER

DECKHAND BOOM

10 m (32,80 ft)
 9 m (29,52 ft)
 8 m (26,24 ft)
 7 m (23 ft)
 6 m (19,68 ft)
 5 m (16,4 ft)
 4 m (13,12 ft)
 3 m (9,84 ft)
 2 m (6,56 ft)
 1 m (3,28 ft)
 0 m (0 ft)

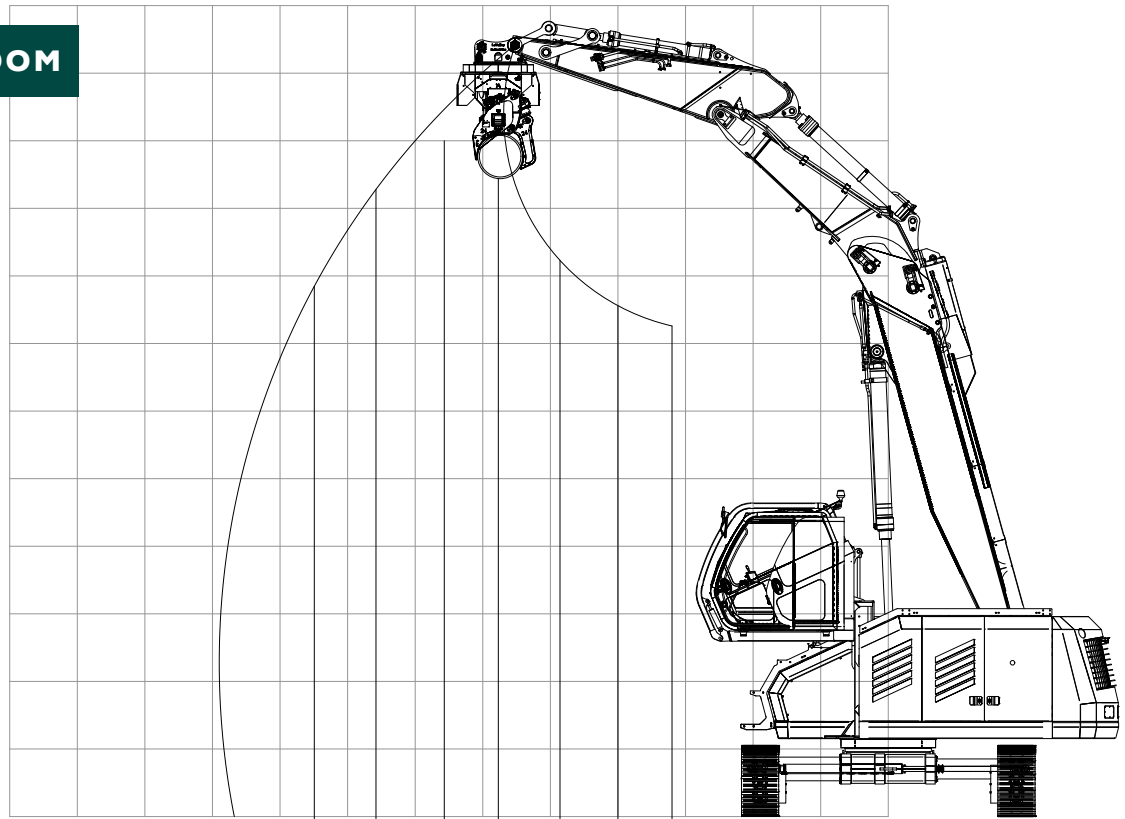

360°

PIPELAYER BOOM

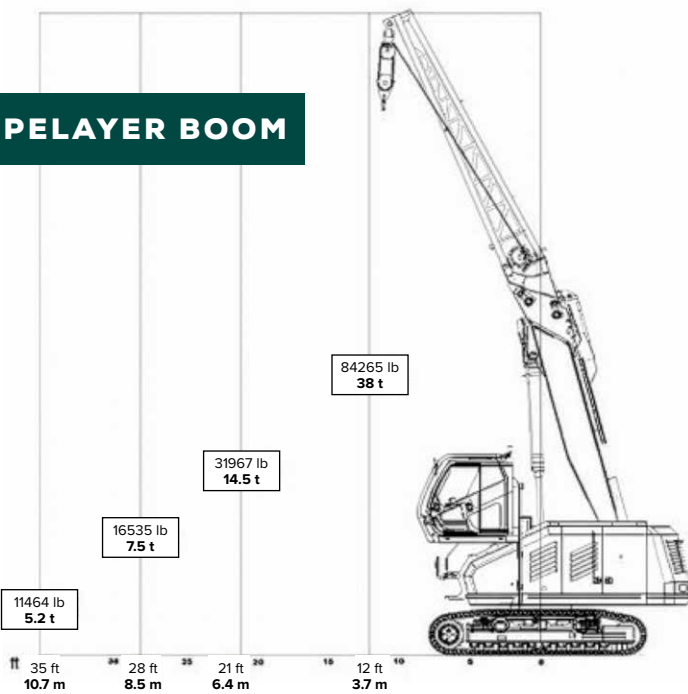

DIGGING BOOM

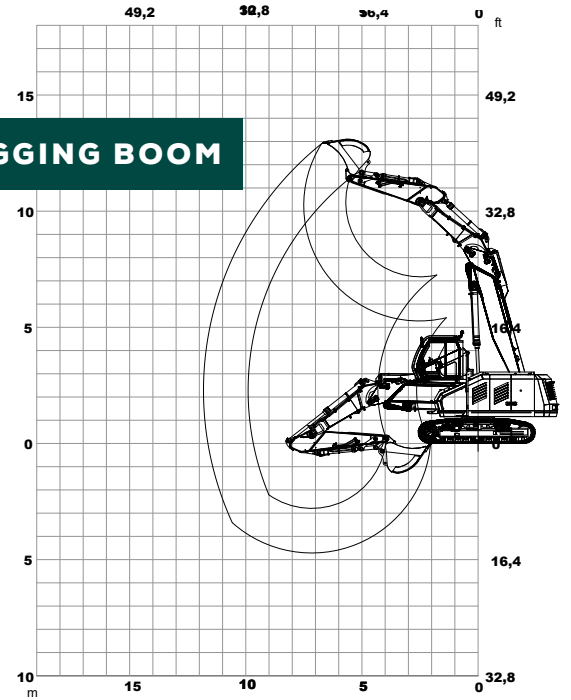

BUILT FOR PIPELINERS, BY PIPELINERS.

Pipeline construction has evolved around equipment designed for other purposes.

The **PIPELINER** marks the transition to a dedicated, integrated, all-in-one pipe handling solution—representing the next evolution in pipeline equipment design.

CONTACT FOR MORE INFORMATION:

218.444.3030 | INFO@LAVALLEYINDUSTRIES.COM



SCAN TO VISIT THE
PIPELINER PAGE AT
LAVALLEYINDUSTRIES.COM

